

DCU 305 R3 LT Engine Controller



At a glance

- 12 channels for configurable switch inputs
- 5 channels for configurable 4-20 mA inputs
- Integrated Independent Shutdown unit
- Can be used in four different main operation modes
- 4 speed relays allowing RPM dependent set points
- Secure Event Log records all activities
- 2 channels for configurable 24 VDC inputs
- 2 configurable relay outputs
- IACS certified and approved by major classification societies

Why customers select the DCU 305 R3 LT

- Cost effective controller for gas- and diesel engines without an electronic control module, ECM
- Classification Society approved by several major IACS society members
- Simple clear display with easy menu structure
- Configured with user-friendly, free to download Windows(tm) software
- Two-unit construction, supplied with "Plug & Play" cables
- Remote panel kit available that can monitor up to four DCU 305's



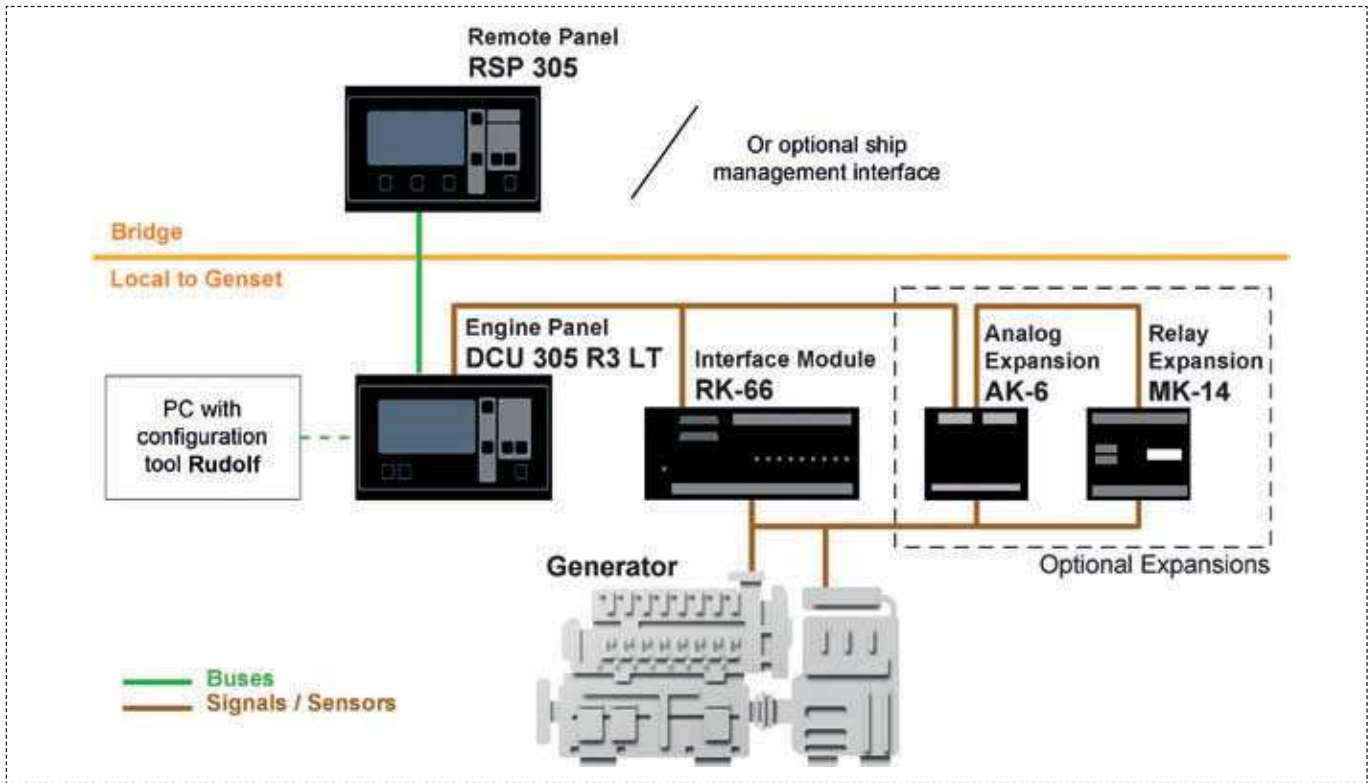

Features and Benefits

Proven and Effective

- Thousands in service
- Rugged construction and IP54 front
- IACS certified
- Quick and easy installation and configuration

Expandable

- Analog channels expandable to 11, using the AK-6 unit
- Relay channels expandable to 16, using the MK-14 unit
- Configured via same tool
- Remote panel kit available
- Ready to communicate with ships alarm system

Independent Shutdown

- Built into main unit to reduce complexity
- Built-in hard switches protect engine in case of main CPU failure
- Overspeed test facility built-in
- Two channels for magnetic pickups

Simple configuration Tool

- Configuration can be made without access to the unit
- Each channel can be named and given several custom set-points
- Service events can be programmed
- Downloadable secure Event Log for accountability

Ordering Info

ITEM	PART NUMBER
DCU 305 R3 LT (complete, inc. RK-66 and cables)	1006420
AK-6 Analog expansion module	1075268
MK-14 Relay expansion module	1121341
RSP 305 Remote Panel kit	1006501

www.auto-maskin.com



RTNA

