

# Marine Pro 400 Series DCU 410E Engine Controller



## At a glance

- 5.7" Colour screen with high resolution and colour definition
- 1GHz Dual Core CPU provides lightning response
- 8 configurable switch inputs
- 4 configurable 4-20mA inputs
- 4 configurable PT100 inputs
- Dual J1939 interfaces
- 2 0-5V inputs
- Ethernet and Modbus communication

## Why customers select the DCU 410E

- Hi resolution colour display presents data clearly and precisely
- Selectable languages means operator understands the data
- Accepts multiple sensor standards and outputs
- Intuitively configurable using just a web browser
- Provides programmable engine control logic
- Approved by 8 Classification Societies



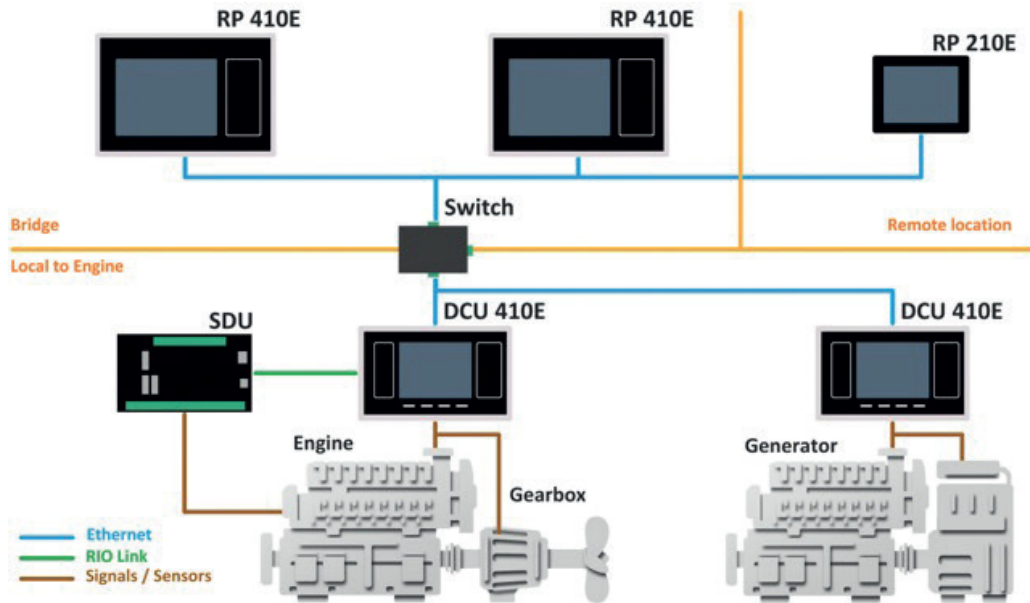

## Features and benefits

Same hardware  
for many  
applications

Can hold more than 40  
customer selectable  
configuration files

Connectable to  
multiple engine types  
and or ships systems

Suitable for fixed and  
variable speed uses

Multiple standard I/Os  
and outputs

No specialist  
skills required

Many languages as  
standard including  
Chinese and Russian

No special tools

No special software, just  
an internet browser

Preloaded configurations

Ability to  
communicate  
with whole ships  
systems

Ethernet connected  
means literally  
Plug & Play

Simple two wire Modbus  
connectivity when needed

Expandable to include  
other vessel parameters

Accountability

Secure historical event  
and alarm list

Displays J1939 faults  
in real text

Can link to third party  
ship management and  
remote systems

Touchscreen provides  
clear precise  
information to operator

## Ordering info

Item	Part number
DCU 410E Engine Controller	1006445
SDU 410 Safety Shutdown Unit	1006451
RP 410E Remote Panel	1006446
RP 210E Remote Panel	1006476

### Sales EMEA and Asia

Phone: (+47) 64 84 52 00  
Email: sales@auto-maskin.com

### Sales North and South America

Phone: +1 (832) 738-1024  
Email: sales.us@auto-maskin.com

Managing Energy

www.auto-maskin.com